

RAIN SENSOR INSTALLATION INSTRUCTIONS

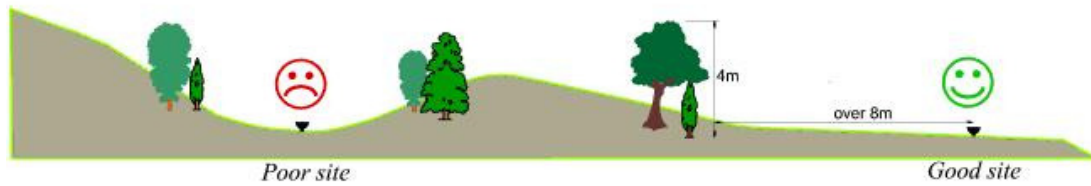

The rain sensor should, ideally, be situated at a distance of twice the height of local obstructions and mounted 30cm (12") above ground level. This requirement can often be difficult or impossible to achieve due to surrounding bushes, trees etc. For most practical purposes accuracy will not be greatly impaired if the site is only a distance equal to the height of the obstructions.

It is important that the sensor is reasonably accessible as, from time to time, the filter will require cleaning. Very often the top of a fence post provides an excellent site so long as it is firm, clear of bushes and trees above.

It is wise to avoid mounting on or near buildings which can cause wind turbulence and create dust. Avoid also mounting near to transmitter aerials which can in certain circumstances cause interference.

Installation

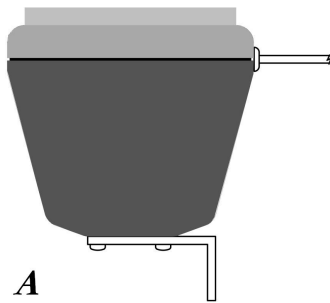

A) Rain sensor for post mounting (standard)

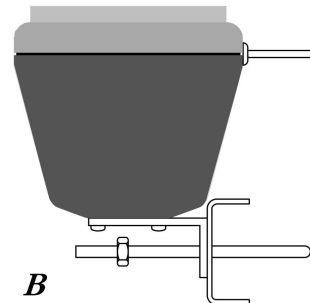

B) Rain sensor for mast mounting (additional kit required: 480 1000 125)

Screw the mounting bracket to a **firm and rigid** post, fence or wall ensuring that the funnel opening is absolutely horizontal. Ensure also there is at least **5mm clearance** between the **bottom of the bowl and any surface below**.

To avoid the possibility of water running down the cable and into the sensor, it is important that the cable drops away from the bowl. Leave some slack in the cable beneath the sensor to facilitate cleaning.

Now lay out the cable to the control box avoiding close proximity to power and transmitter cables. Be very careful not to nick the cable when being clipped to walls etc. If the cable is to be buried, then run cable through plastic hose etc to avoid vermin biting through cable.

Maintenance

From time to time dust and other foreign bodies will accumulate on the funnel filters.

To Clean;- carefully withdraw filter and sponge and clean under a tap.

Important – avoid touching the stainless steel mesh filter with bare fingers as this will deposit grease which may impair the flow of water.

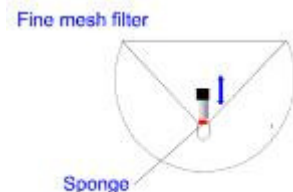

MAINTENANCE & TROUBLESHOOTING

Rain Sensor

The Instromet Rain Gauge will provide superb performance and super sensitivity with a resolution of only 0.01 mm. Unfortunately this sensitivity comes at a small price – the need for regular cleaning of the funnel and filters. The frequency of this cleansing will to a large extent depend on the locality of the site. In very dusty areas, in times of predominantly dry weather, the gauge may well have to be cleaned once a month whereas cleaner areas may only require attention twice a year.

1. Cleaning the gauge

Before any tests are carried out the gauge must be checked for cleanliness.

Remove the sensor from the wall/post bracket by pulling it up off the bracket. **Beware;-** the funnel may have filled with water so there is a danger of spillage! Pull out the filter post, which, if fitted, will reveal either a red filter sponge or a wire gauze disc filter. The sponge can be removed, preferably, with a pair of tweezers or small screwdriver. The wire gauze will have to be prised out carefully with again a small screwdriver. At this point it would be advisable to wash the funnel and filters out with warm water and detergent, a small brush will be useful here. It should now be possible to see a very small hole (less than 1 mm diameter) in the centre of the funnel bottom. If not clear a piece of wire (eg a paper clip straightened out or a medium sized sewing needle) should be pushed through any mire that may have stuck to the bottom. If the unit has a clear tube fitted at the bottom it will be worth looking at the condition of this. If it is looking generally clear then no further action will be required. If, however, the clarity of the tube is severely impaired by algae then running water with diluted bleach or other cleansing fluid through it several times will be worthwhile. Beware; do not allow the diluted bleach to come in to contact with your skin or clothes. Once all is clean and water will pass through the gauge replace the filters and re-mount the gauge on its bracket. Check again that water passes through by emptying a teaspoon full of water into the funnel. It may take a minute or two but water should eventually drip out of the bottom.

2. Testing the gauge

Be sure to reset the Rainfall counter to zero before each test

Assuming that water has passed through satisfactorily as above, the unit can now be tested for accuracy.

What is required is to drip 5 ml of water into the funnel over a period of approximately one minute to simulate the rate of normal rainfall. Introducing large amounts of rainfall in one go will result in inaccurate results.

5ml of water introduced should produce a reading of 1.00 mm

A 5 or 10 mm syringe is ideal as a measuring device as the water can be measured accurately and dispensed slowly.

Alternatively, although less accurate, a 5ml medicine spoon will do the same job although controlling the rate at which the water is dispensed will be difficult.

3 Fault Finding

If the testing above results in no readings being recorded then the following procedures will assist in locating the source of the problem. Identify where the cable from the rain sensor is connected within the building be it to a junction box or to the back of the display itself. Disconnect the Yellow wire (White if screened cable) from the sensor.

Reset the counter.

With a short piece of wire connected to the Yellow terminal (make sure terminal screw is tight) short circuit several times to the Red terminal that also leads to the Rain gauge.

This should result in a count on the display. If not; repeat the test ensuring that the power is on and if still no success the problem will lie in the display or cable/connections leading from the junction box to the display.

If the display counter has now advanced from zero then the cause of the problem will be due to either the integrity of the cable or connections, or the rain gauge itself. **Reconnect the yellow wire.** To test the cable it must first be disconnected from the gauge. Remove the small securing screw from the base of the gauge bowl and separate the two halves around the equator. Identify and unplug the cable from the printed circuit board.

Ensure yellow wire is properly reconnected, power is on and Reset the counter.

Using a short piece of wire (a paper clip suitably bent will suffice) short out several times the **Yellow and Red wires on the cable**. The wire link can be pushed into the appropriate holes on the connector if fitted. This should result in a count of several digits on the Rain display. If not, the cable is suspect and needs to be thoroughly checked. If the cable is buried beware of rodents who may have bitten through it. If a count is recorded then the problem is almost certainly the gauge itself. Inspect the printed circuit board for corrosion and damage to the clear tube if fitted. If nothing obvious is observed then introduce a small amount of water into the funnel and watch to see if it emerges in discreet droplets – be sure to keep the funnel top horizontal while carrying out this test. If the water does not emerge correctly try cleaning unit again.

If all else fails call service department **01692 502800** or return the sensor to us for checking or replacement.